



Over the past decade, Elm Electronics has helped many experimenters that were having trouble getting their circuits working. Experience has shown that the majority of problems were related to the incorrect connection of transistors in the circuit. Even the most seasoned of experimenters have problems with this, as there is no single standard for pinouts, and the transistor pins are not usually marked.

The following discussion shows how you might test NPN and PNP transistors in order to identify the three leads.

The transistor Model

It is often claimed that transistors can be identified using only a multimeter that has a diode test function (on some, the ohmmeter function will work as well). This type of test is based on the assumption that a transistor can be considered to be two diodes connected at the base and extending to the emitter and collector. That is, for an NPN transistor with symbol:

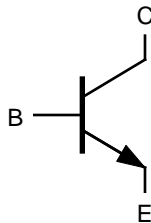

the test assumes a model that is simply two diodes:

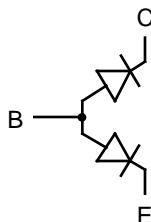

To determine the type of transistor, the meter leads are connected in all combinations until it is found that one of the leads shows two diodes connected to it. For an NPN transistor, the red (positive) meter lead will be on the base at that point, and the black lead will be connected to either the emitter or the collector. For a PNP transistor, the black lead will be on the base, and the red lead shows diodes from the other two leads to it.

This type of test can quickly show what type of transistor you have (NPN or PNP), and it identifies

one of the connections (the base), but it does not help to identify the other two leads.

To be able to tell which of the remaining leads is which requires a small refinement to the simple two diode model. This is done by noting that the circuit between the base and emitter is really a zener diode, while the base to collector connection is more like a standard rectifier diode. The NPN circuit model then becomes:

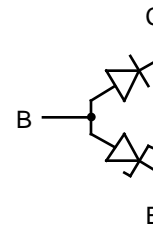

With this model in mind, a test can be created that makes use of the fact that the emitter to base junction will break down (avalanche) at a much lower voltage than the collector to base junction. Typical values for this breakdown voltage are in the range of 6 to 12 volts (while the collector to base junction will typically tolerate about 10 times this), so all that is needed is a source of 12 volts or more.

Figure 1 shows our recommended test circuit for determining all leads of a transistor, whether it is an NPN or a PNP. It uses two 9V radio batteries in series as a source, but any supply of about 15 to 25 volts should work well. Note that the 47 K resistor is a critical element that limits the test current to a safe level.

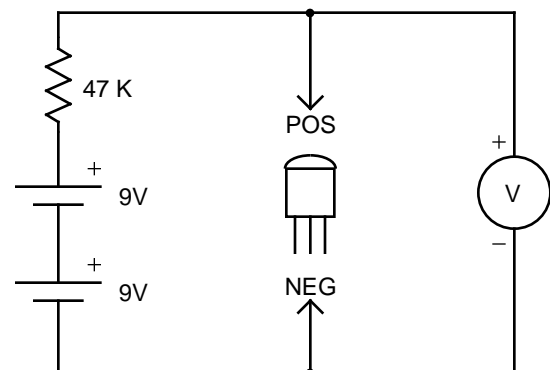

Figure 1. The Transistor Tester

The voltmeter shown connected between 'POS' and 'NEG' does not have to be especially accurate -



virtually any modern digital meter should work for this test.

A permanent test circuit can certainly be made, but we have found that a solderless breadboard is the easiest way to construct this circuit. To the right is a picture of a typical setup. With this system, the solderless breadboard can be used to hold the transistor while you connect the 'POS' and 'NEG' leads to each pin. Also, the voltmeter leads can remain fixed, making it easier to take the necessary readings.

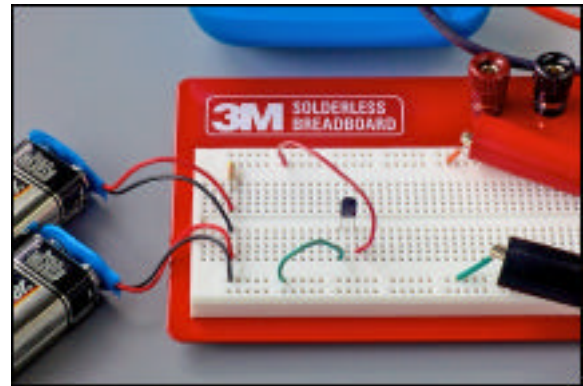

The Test Procedure

The transistor test consists of a series of voltage readings, taken as the 'POS' and 'NEG' connections to the transistor are varied. We have provided a Transistor Test Sheet for these readings on page 4. In all, there are 12 possible voltage readings that can be taken, but with experience, you may find that you do not need to perform all of them.

Begin by considering the three leads to the transistor as X, Y and Z. Connect the POS test wire to the X lead, and the NEG wire to the Y lead, and do nothing with the Z lead (leave it open-circuited). Note the voltage on the meter, and write it down in the box provided. Repeat this type of testing for all of the combinations, as shown on the Transistor Test Sheet. When you are complete, you will have a set of readings similar to those shown on page 3.

Analyzing the results is not that difficult, if you first note that all of the measurements can be broadly classified as high, medium or low voltages. Using the results of page 3 as an example, the first two readings are 7.08V and 7.68V. These are both at a medium level. Similarly, the next two voltages are 0.66 V and 0.64V, both a low voltage, while the next two are at a high level. The results for these six tests (labelled 'NPN Tests') are all in pairs (M-M, L-L, and H-H).

Looking at the next six readings (labelled 'PNP Tests') it appears that the results are not in pairs, but are rather randomly distributed. This means that the PNP model is not appropriate for this transistor, and that the transistor is actually an NPN.

The transistor type is determined by the test that produces pairs of results.

Once you know the type of transistor that you are testing, it is a simple matter to determine which lead is which, based on the measured voltages. The transistor pinout is determined as follows:

The lead represented by the highest voltage pair is the Collector. In the page 3 example, this is Z.

The lead represented by the lowest voltage pair is the Base. In the page 3 example, this is Y.

The lead represented by the medium voltage pair is the Emitter. In the page 3 example, this is X.

This procedure and the analysis of the results work whether the transistor you are testing is an NPN or a PNP type. Simply perform the tests, noting which group (NPN or PNP) produces pairs of results, then determine the pins based on the measured voltages.

We hope that this information helps, and possibly prevents construction problems from occurring. If you have any comments on this Application Note, or would like to see one on another topic, please tell us in an email to feedback@elmelectronics.com.



Leave X connected to POS for both tests

Transistor Test Sheet

part no.: 2N3904

NPN Tests

X to POS

Jumper from NEG to the Y lead, and leave Z open

Jumper from NEG to the Z lead, and leave Y open

Y	Z	Voltage
NEG	-	7.08
-	NEG	7.68

Measure from POS to NEG

This pair matches as both are at a medium voltage level

Y to POS

Y	Z	Voltage
NEG	-	0.66
-	NEG	0.64

This pair matches as both are at a low voltage level

Z to POS

Y	Z	Voltage
NEG	-	18.6
-	NEG	18.6

This pair matches as both are at a high voltage level

Since these pairs all match, this TRANSISTOR IS AN NPN

These voltages are at the medium level, so: X IS THE EMITTER

These voltages are at the low level, so: Y IS THE BASE

These voltages are at the high level, so: Z IS THE COLLECTOR

PNP Tests

X to NEG

Y	Z	Voltage
POS	-	0.66
-	POS	18.6

This pair does not match as one is at a low voltage and the other is at a high voltage

Y to NEG

Y	Z	Voltage
POS	-	7.09
-	POS	18.6

This pair does not match as one is at a medium voltage and the other is at a high voltage

Z to NEG

Y	Z	Voltage
POS	-	7.68
-	POS	0.64

This pair does not match as one is at a medium voltage and the other is at a low voltage

These pairs do not match, so this TRANSISTOR IS NOT A PNP

device sketch:

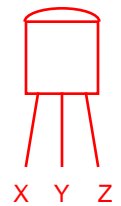

When pairs match:
High -> Collector
Med -> Emitter
Low -> Base



Transistor Test Sheet

part no.: _____

NPN Tests

X to POS

Y	Z	Voltage
NEG	-	
-	NEG	

Y to POS

Y	Z	Voltage
NEG	-	
-	NEG	

Z to POS

Y	Z	Voltage
NEG	-	
-	NEG	

PNP Tests

X to NEG

Y	Z	Voltage
POS	-	
-	POS	

Y to NEG

Y	Z	Voltage
POS	-	
-	POS	

Z to NEG

Y	Z	Voltage
POS	-	
-	POS	

When pairs match:
High -> Collector
Med -> Emitter
Low -> Base