

# ELM334

## Garage Doorman

### Description

The ELM334 is an integrated circuit for remotely monitoring the position of electrical contacts (on a garage door, for example) and reporting the position by way of coloured LEDs. A two-wire interface is all that is needed to convey the position of the door to two remotely located LEDs, and to also provide pushbutton control for an electric opener if desired.

This circuit is able to monitor the state of one or two position sensing switches, provide debouncing of the signals, and to generate an alternating (flashing) output when the position changes. In addition, there is a separate pushbutton input that may be used to control an electric garage door opener, or possibly trigger an alarm.

Several examples of how the ELM334 might be used are provided in the Example Applications section.

### Features

- Low power CMOS design
- Wide supply range - 3.0 to 5.5 volt operation
- Simultaneous monitoring of three inputs
- Fully debounced inputs
- Two wire interface to LEDs
- Stuck button protection on the control output
- Pulsed control output

### Applications

- Garage door monitoring and control
- Remote signalling and acknowledgement
- Remote alarm circuits

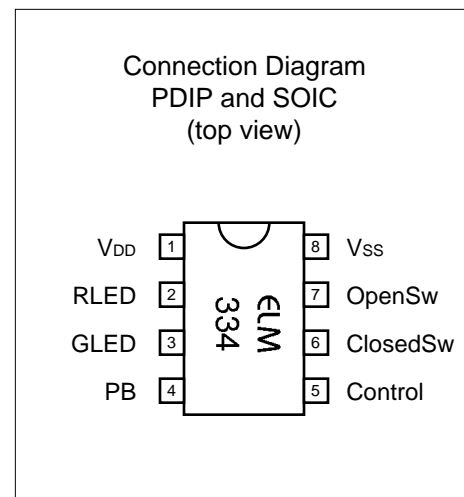

### Block Diagram

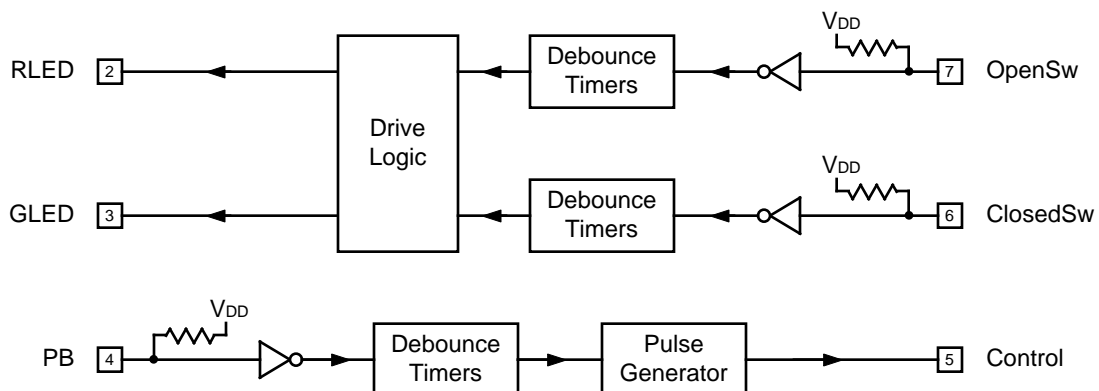



**Pin Descriptions**

**V<sub>DD</sub> (pin 1)**

This pin is the positive supply pin, and should always be the most positive point in the circuit. Internal circuitry connected to this pin is used to provide power-on reset of the microprocessor, so an external reset signal is not required. Refer to the Electrical Characteristics section for further information.

**RLED (pin 2), and GLED (pin 3)**

These two outputs are for driving LEDs (through a suitable current limiting resistance). Logic ensures that only one output is active at a time, allowing the two outputs to drive a single dual type LED (that is red if energized in one polarity, and green if the polarity is reversed). During powerup, the red LED will be lit for 0.5 sec, followed by the green for 0.5 sec, as a LED test.

**PB (pin 4)**

A momentary low level on this pin will be debounced, and then used to initiate a 0.5 second output pulse on pin 5. If unused, it is preferable to connect this pin to V<sub>DD</sub> (but it may be left open-circuited, as there is an internal pullup resistor).

**Control (pin 5)**

An active high level pulse will appear at this pin, in response to a low level on pin 4. Only a single 0.5 sec pulse will be output, regardless of the length

of time that the pin 4 input remains low (as long as it is greater than the 26 msec debounce time). The state of the RLED and the GLED lines is not updated if the pushbutton is being pressed.

**ClosedSw (pin 6), and OpenSw (pin 7)**

These two inputs are for monitoring the position of the door (or other contacts). Since these switches might be attached to some very simple switch mechanisms, a long 0.5 sec debounce timer (pickup and dropout) is used on each input. This allows the LED outputs to possibly be used with logic circuits, as well as driving LEDs.

The OpenSw input is not required for circuit operation. If this input is not used, the LEDs will still flash alternately when the door is opened, but after 30 seconds, the flashing will stop and the red LED will light solidly. Please refer to the Circuit Operation section for more details.

If either pin 6 or pin 7 are not used, it is preferable to connect them to V<sub>DD</sub> (but they may be left open-circuited, as they both have internal pullup resistors).

**V<sub>SS</sub> (pin 8)**

Circuit common is connected to this pin. This is the most negative point in the circuit.

**Ordering Information**

These integrated circuits are available in either the 300 mil plastic DIP format, or in the 208 mil SOIC surface mount type of package. To order, add the appropriate suffix to the part number:

300 mil Plastic DIP..... ELM334P

208 mil SOIC..... ELM334SM

All rights reserved. Copyright ©1999, 2008 Elm Electronics.  
Every effort is made to verify the accuracy of information provided in this document, but no representation or warranty can be given and no liability assumed by Elm Electronics with respect to the accuracy and/or use of any products or information described in this document. Elm Electronics will not be responsible for any patent infringements arising from the use of these products or information, and does not authorize or warrant the use of any Elm Electronics product in life support devices and/or systems. Elm Electronics reserves the right to make changes to the device(s) described in this document in order to improve reliability, function, or design.





## Circuit Operation

The ELM334 can be thought of as two inverters that have some additional logic connected. The inputs to the inverters are located on pins 6 and 7, while the outputs are connected to pins 2 and 3. If pin 7 is connected to a low level, then pin 2 goes high. If pin 6 is connected to a low level, pin 3 will go high. There are several additions, however, that make these a little more than simple inverters.

To make this IC more useful, we have added 'debounce' circuits to the pin 6 and 7 inputs. These are similar to digital integrators - the input must be at one level for a set time before the output can change. This may not be necessary for simple LEDs, but if you want to interface to a computer circuit or other logic, you will require a clean signal such as this provides. To ensure that the circuit works reliably even with very poor quality switches, a debounce period of 0.5 seconds is used.

In addition to the debouncing, there is logic connected to these pins, so that both LEDs are not on at the same time, etc. (the door is either closed or open, but not both). Figure 1 shows the outputs that can be expected for all combinations of the two inputs.

Typically, a dual red/green LED will be connected between the two output pins, and this is what is meant by the last column. You may connect separate LEDs

between each output and circuit common, but there is no advantage to this, as it requires an extra wire for remote indicators. (It is easier and cheaper to wire separate LEDs 'back to back' as shown in the Example Applications section.)

One other feature of the internal logic is a 'lamp test' that is performed at each power up - the LEDs are each turned on for 0.5 seconds so that you can be sure that they are both working (red first, followed by green).

The ELM334 also has a special pushbutton circuit connected between pins 4 and 5. When a low level input appears on pin 4, a 0.5 second pulse will be output on pin 5. This is typically used to drive a relay which interfaces with the garage door control circuit, but it can also be connected to logic of your choice. Only one pulse will be generated for each pushbutton press, no matter how long the button is held for. The input also provides a debouncing circuit so that a mechanical pushbutton can be used.

That covers the basics of how the ELM334 IC operates. The next section (Example Applications) shows a few examples of how it may be used...

Pin 6 ClosedSw	Pin 7 OpenSw	Pin 2 RLED	Pin 3 GLED	Dual (R/G) LED glows
L	H	L	H	Green
H	L	H	L	Red
L	L	L	H	Green
H	H	Alternates between red and green for 30 seconds, then shows red		

Figure 1. ELM334 LED Logic



## Example Applications

The following pages show a few circuits that may help you get started with the ELM334. They show everything from a minimal circuit to a typical full implementation that you may wish to try. We encourage experimentation, and hope that you enjoy doing so.

The first circuit (Figure 2) shows the absolute minimum required to use the ELM334 IC. A single (normally closed) contact is connected between pin 6 and circuit common, while a single green LED is connected between pins 2 and 3. We do not use a current limiting resistor in series with the LED, as the ELM334 has fairly high output resistance when operated with a 3V supply, and will limit the LED current. Two 'AA' batteries in series provide the 3V source to operate the circuit.

Normally, the door closed switch is closed when the door is, and opens when the door does (this could

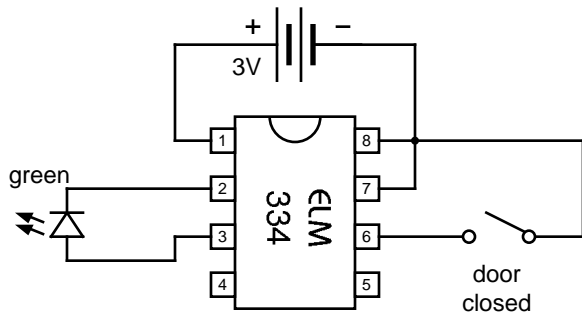

Figure 2. Absolute Minimum ELM334 Circuit

be a magnetic switch, or a mechanical contact). When the door opens then, the contact does too, and the pin 6 input goes high. With the pin 7 input low, the green LED will turn off (see Figure 1 for the pin logic). If we had connected a dual red/green LED, the red LED would turn on when the door opens.

Figure 2 would likely work well if experimenting on the bench, but really requires more circuitry to make it more reliable for 'real world' operation. Figure 3 shows the recommended additions to make a more reliable circuit. Note that we have now shown a ground symbol to represent the circuit common (battery negative), just to simplify the schematic. This new circuit shows a capacitor across the IC supply terminals, to prevent noise generated internally by the ELM334 from affecting the supply voltage, and thus the complete circuit. We've also added a few resistors on both the input and the output sides of the IC, mostly to protect it from the effects of induced voltages and currents which can cause a phenomenon called 'latch-up' in some CMOS circuits. If the door closed switch or the LED is more than a few feet away from the ELM334, these extra resistors should be added.

Functionally, the circuit in Figure 3 operates in exactly the same manner as the one in Figure 2.

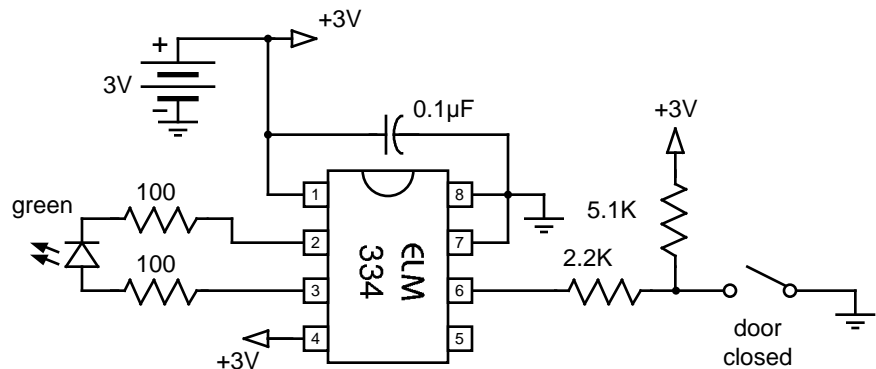

Figure 3. A Better Minimal ELM334 Circuit



## Example Applications (continued)

Figure 4 carries the circuit of Figure 3 a little farther, creating an alarm type circuit. We have used a dual red/green LED this time, and also connected the green LED output to the pushbutton input. In this way, a momentary opening of the door switch will create a pushbutton input, when the green LED goes off. Once the green LED is off, it will remain that way, even if the door contact should close (as internally a pushbutton input always forces the green LED off, and the red LED on). Note that there will be a 0.5 second pulse at the Control output (pin 5) when the door first opens - this might be used to trigger an audible alarm.

This monitor circuit could be used for a door of any type, not just a garage door. Perhaps a shed, or a storage bin. A contact such as from a thermostat could also be connected to warn that a temperature has gone above or below a set limit. To reset this circuit requires turning the power off then on.

The circuits so far have used a battery to supply power. The problem with this is that a pair of AA cells will only last a week or two in such an application. To avoid always having to monitor the monitor, it would be good to power the circuit from a different supply that is derived from the main AC service. Figure 5 on the next page shows a circuit that assumes you are able to obtain 12V from a source (most likely an AC adapter). This allows generating a 5V supply for the ELM334 while also providing a higher voltage that is suitable for driving a relay (from the Control output).

Operation of the LED portion of Figure 5 is very similar to the previous circuits, except that we have

now added a switch to indicate that the door is fully open. The position sensing switches (possibly magnetic reeds) are connected to the 5.1K pullup resistors in order to provide a full logic swing input to the ELM334 as they operate. The 2.2K series resistors provide some protection for the chip as the wires to the switches are likely to be lengthy, and susceptible to induced voltages and currents. After processing, the appropriate voltages appear at pins 2 and 3, driving the LEDs through the 150 current limiting resistors. Since the supply is now 5V, we have increased the LED resistors slightly in order to maintain roughly the same current.

The control portion of the circuit may appear to be a little odd-looking at first. To understand its operation, note that one of the two driven LEDs is always on, whether flashing or solid. Due to the connection of the two NPN transistors then, one of the NPNs is always biased on, keeping the PNP on, and pin 4 of the ELM334 at 5V. When the remote pushbutton is pressed, the LED circuit is shorted out, and neither NPN can conduct. The PNP thus shuts off, and pin 4 of the IC drops to 0V, its active level. With the PB input active, a pulse is output at pin 5, causing the relay to pick up for 0.5 seconds.

Although this circuit was designed to monitor doors, there are likely to be many other applications that it can be adapted to. Monitoring thermostats, or light levels, or water levels, for example.

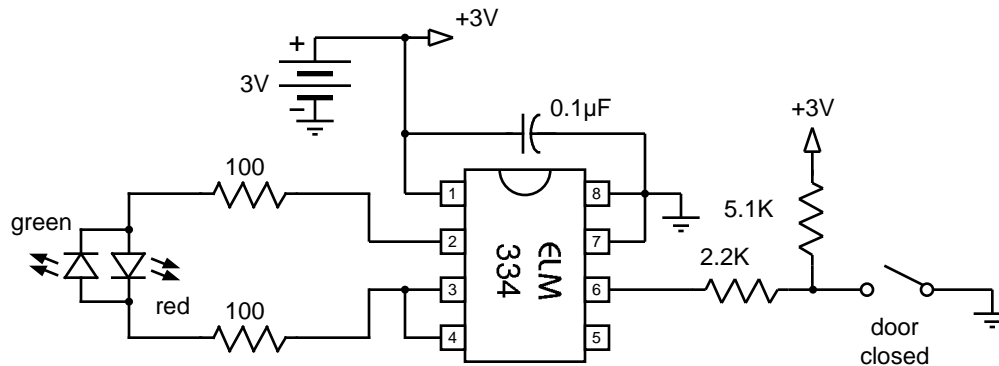

Figure 4. A Remote Monitor with Memory



### Example Applications (continued)

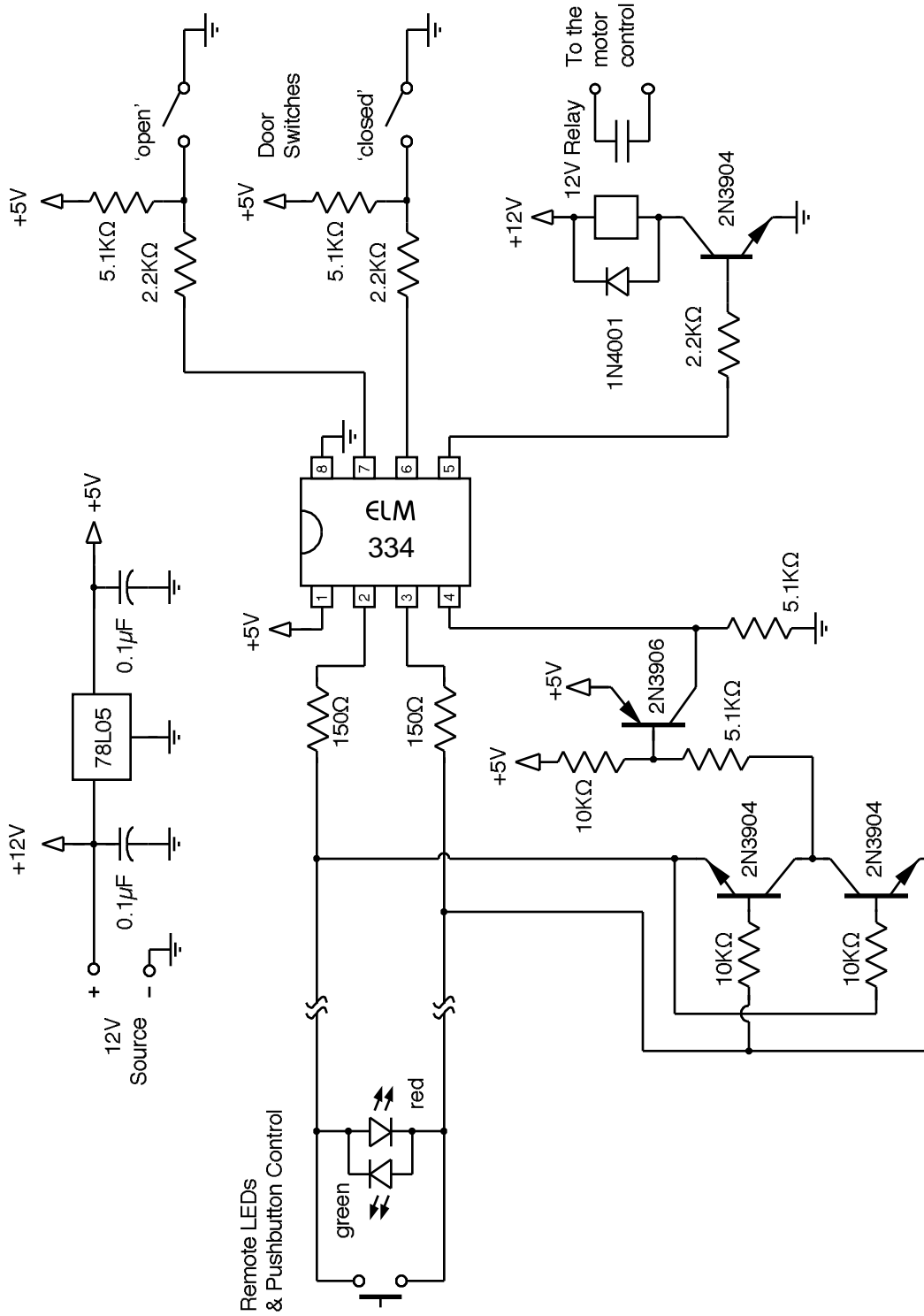

Figure 5. A Complete Monitoring and Control Circuit