



ELM337

Light Switch

Description

The ELM337 provides a convenient means to interface standard photocells or light dependent resistors (LDRs) to digital logic circuits. It provides an input comparator with hysteresis, line frequency filtering, digital delays, and high current output drivers all within the one 8 pin package.

Three mode setting pins configure the ELM337 for pulse or continuous output and for a delay on change of from 1 msec to 10 minutes. The transition threshold is set with a single external resistor, simplifying designs and minimizing costs.

Applications need not be limited to those employing photocells, as the Example Applications section shows. The Schmitt trigger input provides a convenient way to interface to virtually any input signal, whether from digital logic or from a slowly varying analog source. The remainder of the ELM337 can simply be thought of as a time delay on pickup and dropout type circuit - very useful for sequencing processes.

Applications

- Automatic lighting controls
- Security light beam monitoring
- Position sensing
- Light controlled counters
- Time delay circuits

Features

- Low power CMOS design - typically 1mA at 5V
- Operates from 3V to 5.5V
- No external timing elements required
- Low parts count
- Digitally selected delays of up to 10 minutes
- Pulsed or continuous outputs
- Internal line frequency filtering
- High current drive outputs - up to 25 mA

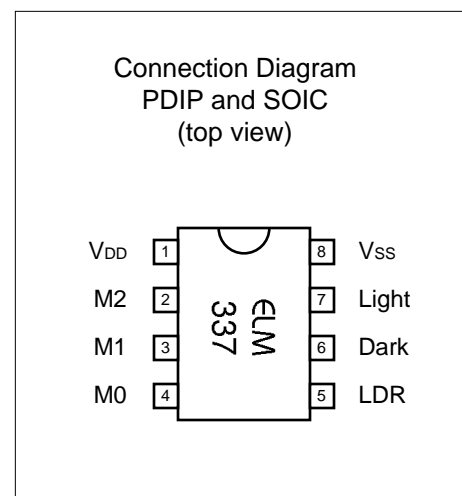

Block Diagram

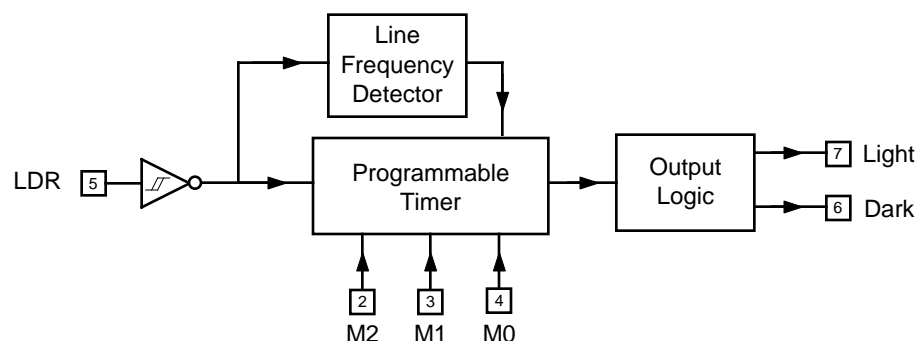



Pin Descriptions

VDD (pin 1)

This pin is the positive supply pin, and should always be the most positive point in the circuit. Internal circuitry connected to this pin is used to provide power on reset of the microprocessor, so an external reset signal is not required. Refer to the Electrical Characteristics section for further information.

frequency filtering so that slowly varying and pulsating signals will not cause circuit instability. A logic low level on this pin will be interpreted as the presence of light, while a logic high results in a dark input. See the Example Applications section for typical connections.

M2 (pin 2), M1 (pin 3) and M0 (pin 4)

The digital levels at these pins determine the mode of operation, as shown in Table 1 below. Levels are read whenever the LDR input signal changes, so that modes can be changed 'on the fly'.

Dark (pin 6) and Light (pin 7)

These are the two active high circuit outputs. Depending on the mode selected, they will either remain continually active, or provide a 50 msec pulse output on change from light to dark (Dark output) or dark to light (Light output).

LDR (pin 5)

This is the voltage sensing input pin. It uses Schmitt trigger circuitry, and a peak detecting circuit for line

Vss (pin 8)

Circuit common is connected to this pin. This is the most negative point in the circuit.

Mode Inputs			Delay on Transition to		Type of Output
M2	M1	M0	Light	Dark	
L	L	L	1 msec	50 msec	Continuous
L	L	H	50 msec	1 msec	Continuous
L	H	L	50 msec	50 msec	Pulse
L	H	H	50 msec	50 msec	Continuous
H	L	L	10 sec	10 sec	Pulse
H	L	H	10 sec	10 sec	Continuous
H	H	L	10 min	10 min	Pulse
H	H	H	10 min	10 min	Continuous

Table 1. Modes of Operation

Ordering Information

These integrated circuits are available in either the 300 mil plastic DIP format, or in the 200 mil SOIC surface mount type of package. To order, add the appropriate suffix to the part number:

300 mil Plastic DIP..... ELM337P

200 mil SOIC..... ELM337SM

All rights reserved. Copyright ©2000 Elm Electronics.

Every effort is made to verify the accuracy of information provided in this document, but no representation or warranty can be given and no liability assumed by Elm Electronics with respect to the accuracy and/or use of any products or information described in this document. Elm Electronics will not be responsible for any patent infringements arising from the use of these products or information, and does not authorize or warrant the use of any Elm Electronics product in life support devices and/or systems. Elm Electronics reserves the right to make changes to the device(s) described in this document in order to improve reliability, function, or design.



Absolute Maximum Ratings

Storage Temperature..... -65°C to +150°C
 Ambient Temperature with
 Power Applied..... -40°C to +85°C
 Voltage on V_{DD} with respect to V_{SS}..... 0 to +7.5V
 Voltage on any other pin with
 respect to V_{SS}..... -0.6V to (V_{DD} + 0.6V)

Note:

Stresses beyond those listed here will likely damage the device. These values are given as a design guideline only. The ability to operate to these levels is neither inferred nor recommended.

Electrical Characteristics

All values are for operation at 25°C and a 5V supply, unless otherwise noted. For further information, refer to note 1 below.

Characteristic	Minimum	Typical	Maximum	Units	Conditions
Supply voltage, V _{DD}	3.0	5.0	5.5	V	
V _{DD} rate of rise	0.05			V/ms	see note 2
Average supply current, I _{DD}		1.0	2.4	mA	
Input low voltage	V _{SS}		0.15 V _{DD}	V	Mode pins
Input high voltage	0.85 V _{DD}		V _{DD}	V	Mode pins
LDR input threshold voltages	to dark 0.75	2.8 1.3	4.25	V V	
Output low voltage			0.6	V	Current (sink) = 8.7mA
Output high voltage	V _{DD} - 0.7			V	Current (source) = 5.4mA
Output pulse width		50		msec	see note 3

Notes:

1. This integrated circuit is produced with a Microchip Technology Inc.'s PIC12C5XX as the core embedded microcontroller. For further device specifications, and possibly clarification of those given, please refer to the appropriate Microchip documentation.
2. This spec must be met in order to ensure that a correct power on reset occurs. It is quite easily achieved using most common types of supplies, but may be violated if one uses a slowly varying supply voltage, as may be obtained through direct connection to solar cells, or some charge pump circuits.
3. As with all of the delays, the Pulse timing is generated internally, and is affected by both temperature and supply voltage. Variations are generally less than 5% of this value over the operating range.

Example Applications

Figure 1 at right shows the ELM337 installed in a typical lighting control circuit. The mode has been set to 111 (or HHH), resulting in delays of 10 minutes when recognizing a light or dark condition. In this case, only the 'Dark' output (pin 6) is used to enable (and disable) a lighting circuit, but other variations on this theme might use the Light output (pin 7), or possibly use mode 110 to provide short (50 msec) output pulses to trigger other circuits.

The threshold setting resistor (22k in Figure 1) is chosen depending on what resistance it is desired to have the transitions to light or dark occur at. Using the typical Schmitt voltage thresholds for a 5 volt supply, it can be shown that the two resistances that switching will occur at are $1.33R_T$ (light to dark) and $0.37R_T$ (dark to light), where R_T is the threshold setting resistance. For the 22k shown, these would be at about 30k and 8k, respectively. The values that you choose would depend on the LDR used, and your application.

If the LDR (R) is mounted more than a few feet from the ELM337, the increased exposure could cause problems due to induced voltages and currents. To provide protection from these, a resistor (R_{prot}) should be added in series with pin 5 as shown at right. Typically this resistor would be equal in value to the threshold setting resistor.

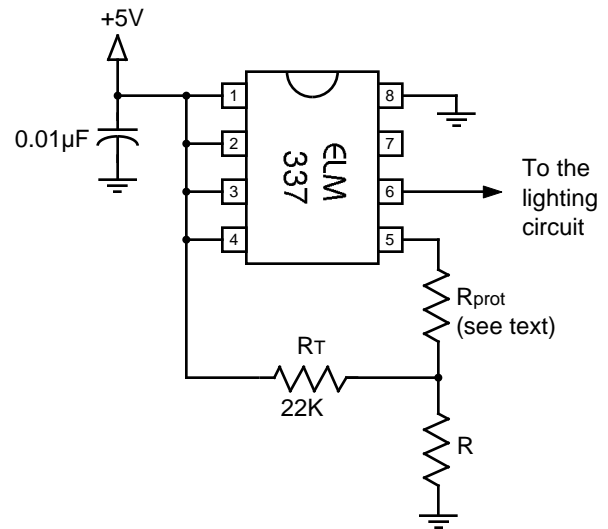

Figure 1. Yard Lighting Controller

The ELM337 is also capable of operating simply as a delay circuit. By hard-wiring the mode pins for a desired delay, and applying logic levels to the LDR pin, symmetrical output delays of up to 10 minutes can be obtained.

Asymmetrical delays can also be obtained as shown in Figure 2. This circuit connects the ELM337 to provide a 50msec delay on pickup and 10 second time delay on dropout function.

Operation of the circuit can best be explained as follows. When the 'start' pushbutton is pressed, the M2 and M1 pins will both be at a logic low level, while M0 will be high. The LDR input is also at a low level, simulating an LDR that is just 'seeing' light. Since the mode is 001 or LLH, then from Table 1 (on page 2) the Light output will go to a high level after 50msec. This delay is desirable as it ensures that the input is legitimate by providing some degree of switch debouncing.

As soon as the pushbutton is released, the M2 mode pin returns to a high level, and what appears to be a dark input will be on the LDR pin. From Table 1, with mode 101, the output will turn off after 10 seconds.

Certainly several other variations are possible by connecting the mode pins in different combinations. Why not try your hand at some...

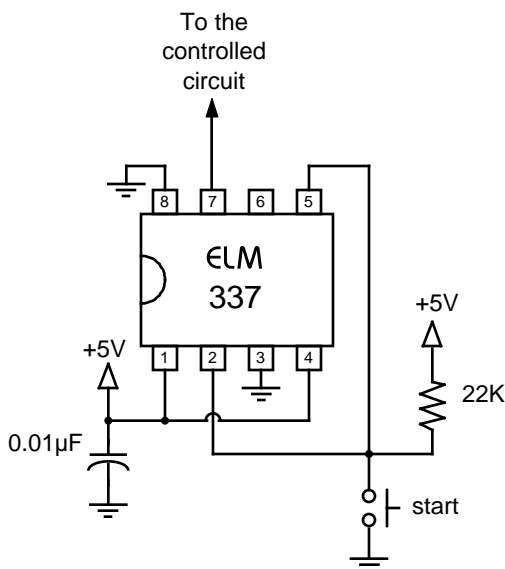

Figure 2. Time Delay Dropout Switch