



ELM339

Infrared Remote Control

Description

The ELM339 is a complete remote control decoder in an 8 pin package. With the addition of a standard infrared receiver module, three individual outputs can be simultaneously controlled using a television remote control transmitter.

This circuit responds to Sony™ television control codes, chosen because most universal remotes default to them when initially powered up. The ELM339 continuously monitors the stream of data from an infrared receiver module looking for these Sony type remote control codes. If an appropriate three digit code is detected, the selected output either turns on, turns off, or switches its state.

One of the outputs can be configured to provide a 250msec pulse output, if desired. This could be useful for interfacing to devices that expect a momentary input, such as garage door controls, alarm test buttons, and some appliances.

Applications

- Basic home automation systems
- Remote smoke alarm test initiator
- Garage door controller
- Lamp controller

Features

- Low power CMOS design - typically 1mA at 5V
- Three separate outputs
- Pulse output for momentary controls
- Signal received output for visual feedback
- Easy interface to standard receiver modules
- Works with universal TV remote transmitters
- High current drive outputs - up to 25 mA

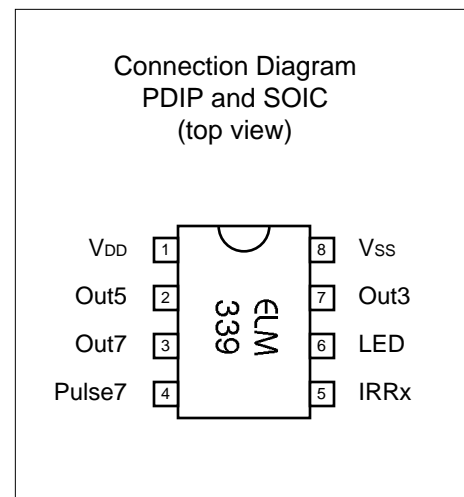

Block Diagram

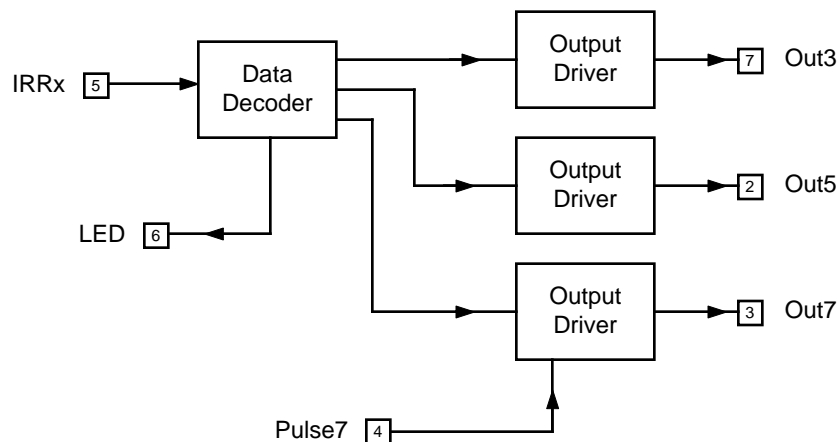



Pin Descriptions

VDD (pin 1)

This pin is the positive supply pin, and should always be the most positive point in the circuit. Internal circuitry connected to this pin is used to provide power on reset of the microprocessor, so an external reset signal is not required. Refer to the Electrical Characteristics section for further information.

Out5 (pin 2)

This output responds to all codes beginning with the sequence 55. It can be forced to a high level by issuing 551, to a low level with 550, and to change state with the sequence 555. It powers up to a logic low level.

Out7 (pin 3)

Out7 responds to all codes beginning with the sequence 77. It can be forced to a high level by issuing 771, to a low level with 770, and to change state with the sequence 777, if the Pulse7 input is at a low level. If Pulse7 is at a high level, a 250msec pulse will be output when any of the three control codes are received.

Pulse7 (pin 4)

This input pin is used to modify the behavior of Out7, as described above. A logic low level applied to this pin results in unmodified behavior

of the output, while a logic high forces Out7 to the pulse mode. Pulse width is nominally 250 msec.

IRRx (pin 5)

The output of a standard 40KHz infrared receiver module is connected to this pin. The output of such a module is normally at a high level, and switches to a logic low when modulated carrier is received. A series resistor of about 5K must be connected between this pin and the infrared module output.

LED (pin 6)

This pin provides a logic high level output when a valid code is being received by the ELM339. It is suitable for driving an LED through a current limiting resistor.

Out3 (pin 7)

This output responds to all codes beginning with the sequence 33. It can be forced to a high level by issuing 331, to a low level with 330, and to change state with the sequence 333. It powers up to a logic low level.

Vss (pin 8)

Circuit common is connected to this pin. This is the most negative point in the circuit.

Ordering Information

These integrated circuits are available in either the 300 mil plastic DIP format, or in the 200 mil SOIC surface mount type of package. To order, add the appropriate suffix to the part number:

300 mil Plastic DIP..... ELM339P 200 mil SOIC..... ELM339SM

All rights reserved. Copyright ©1998 Elm Electronics. Every effort is made to verify the accuracy of information provided in this document, but no representation or warranty can be given and no liability assumed by Elm Electronics with respect to the accuracy and/or use of any products or information described in this document. Elm Electronics will not be responsible for any patent infringements arising from the use of these products or information, and does not authorize or warrant the use of any Elm Electronics product in life support devices and/or systems. Elm Electronics reserves the right to make changes to the device(s) described in this document in order to improve reliability, function, or design.



Absolute Maximum Ratings

Storage Temperature..... -65°C to +150°C
 Ambient Temperature with
 Power Applied..... -40°C to +85°C
 Voltage on V_{DD} with respect to V_{SS}..... 0 to +7.5V
 Voltage on any other pin with
 respect to V_{SS}..... -0.6V to (V_{DD} + 0.6V)

Note:
 Stresses beyond those listed here will likely damage the device. These values are given as a design guideline only. The ability to operate to these levels is neither inferred nor recommended.

Electrical Characteristics

All values are for operation at 25°C and a 5V supply, unless otherwise noted. For further information, refer to note 1 below.

Characteristic	Minimum	Typical	Maximum	Units	Conditions
Supply Voltage, V _{DD}	4.5	5.0	5.5	V	
V _{DD} rate of rise	0.05			V/ms	see note 2
Average Supply Current, I _{DD}		1.0	2.4	mA	see note 3
Input low voltage	V _{SS}		0.15 V _{DD}	V	
Input high voltage	0.85 V _{DD}		V _{DD}	V	
Output low voltage			0.6	V	Current (sink) = 8.7mA
Output high voltage	V _{DD} - 0.7			V	Current (source) = 5.4mA
Out7 Pulse Width	250	260	275	msec	see note 4
Pulse7 Setup Time	0			msec	see note 5

Notes:

1. This integrated circuit is produced with a Microchip Technology Inc.'s PIC12C5XX as the core embedded microcontroller. For further device specifications, and possibly clarification of those given, please refer to the appropriate Microchip documentation.
2. This spec must be met in order to ensure that a correct power on reset occurs. It is quite easily achieved using most common types of supplies, but may be violated if one uses a slowly varying supply voltage, as may be obtained through direct connection to solar cells, or some charge pump circuits.
3. Device only. Does not include any LED or drive currents.
4. Pulse timing is affected by both temperature and supply voltage. Times shown are the widest variation that can normally be expected.
5. The state of Pulse7 is determined after each valid 7 series code is sent. The level need not be set prior to sending the codes.

Example Application

Figure 1 shows a typical control circuit that uses the ELM339. Relays are driven by each of the outputs, providing isolation, and current carrying capability. Transistor buffers are used to interface the circuit to the 12V relays.

All three of the outputs are used in the latching mode, in this case. Converting Out7 (pin 3) to pulse mode is easily accomplished by connecting pin 4 to 5V rather than circuit common as shown. No other circuit changes would be required.

Circuit operation is straight-forward. A serial data stream is detected by the infrared module and passed onto the ELM339 as a series of negative-going pulses. The data is then decoded, and if found to contain the correct Sony™ control code sequence, the state of the selected output will be altered. The receiver modules required are commonly available on the market, and are manufactured by companies such as Sharp™ or

LiteOn™. A 40KHz module is required for a Sony™ infrared remote, although 38KHz ones have been used successfully.

In operation, ambient light can occasionally cause an infrared receiver's bias level to drift towards V_{ss}, possibly tripping the ELM339's schmitt trigger input. As the receiver output drifts high again, the Schmitt trigger may not always reset, so that it might appear that there is carrier present when it is not. This condition is accounted for within the integrated circuit by momentarily changing pin 5 to a high level output before taking any measurements, thus resetting the trigger. The series resistor must be used on pin 5 to protect both circuits during this momentary high level pulse. Typically a value of 4.7K is sufficient.

Power supplies for this application are standard. Regulated 5V is provided for the logic circuits, while unregulated 12V is used for the relay coils.

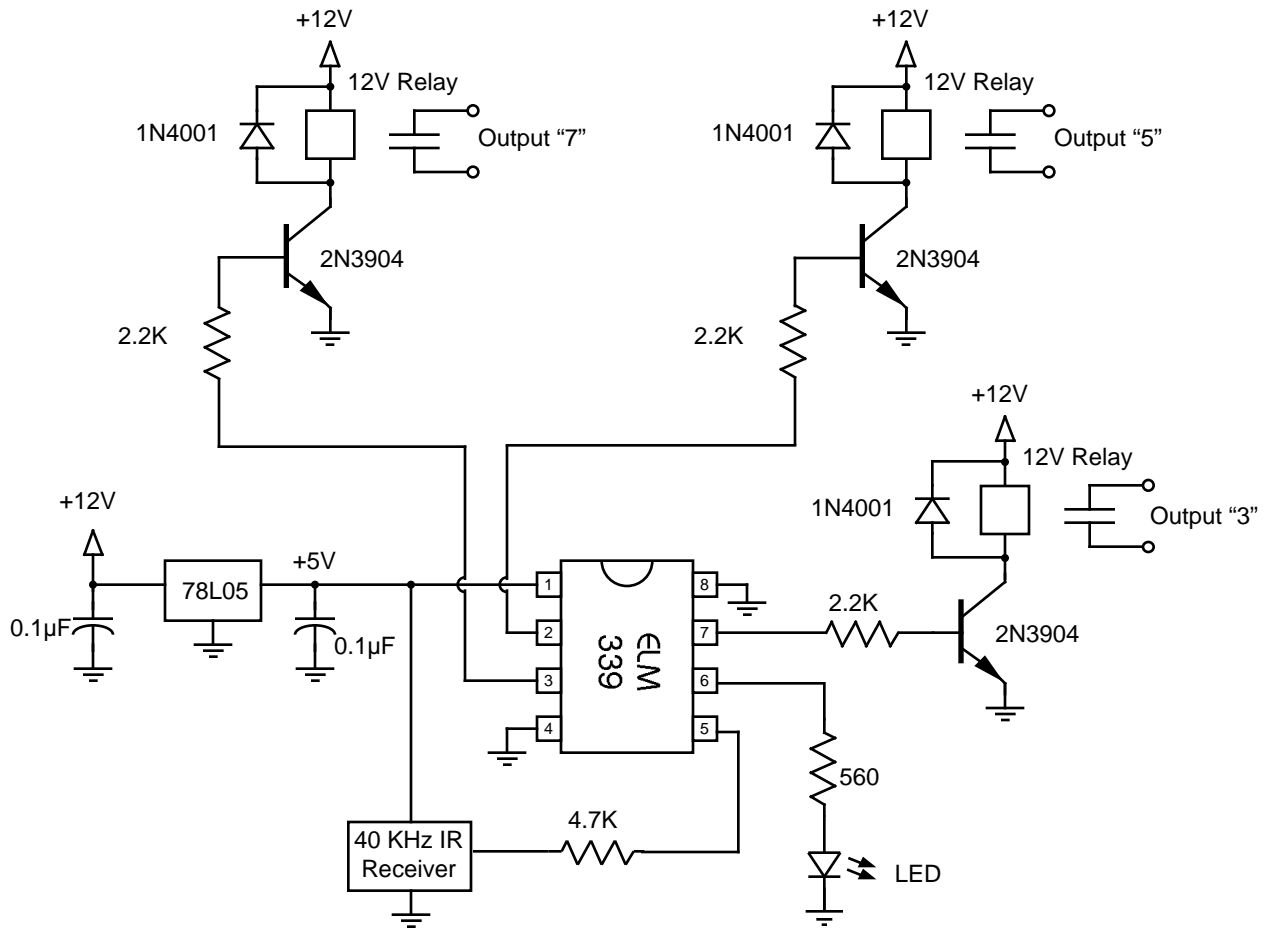

Figure 1. Three Output Remote Control