



Description

The ELM460 is a complete astable oscillator circuit in an 8 pin package. The circuit (impossibly!) requires no external components to operate, as all timing is generated internally.

Immediately after power-up, the ELM460 begins to oscillate continuously at a frequency determined by the logic levels on the configuration inputs. At the end of every period, the circuit again reads these configuration settings, and automatically adapts to any changes that are made.

Two outputs are provided, an active high output and it's logical inverse. The circuit output is always a 50msec pulse, independent of the time period selected.

Features

- Requires no external components
- Low power CMOS design - typically 1mA at 5V
- Wide supply range - 3.0 to 5.5 volt operation
- Provides periods from 0.1 to 600 seconds
- High current drive outputs - up to 25 mA

Applications

- Time Base Generator
- Power Gating Controller
- LED Flasher
- Programmable Timer

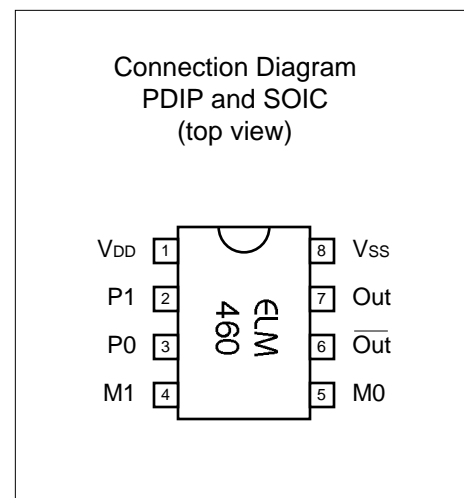

Block Diagram

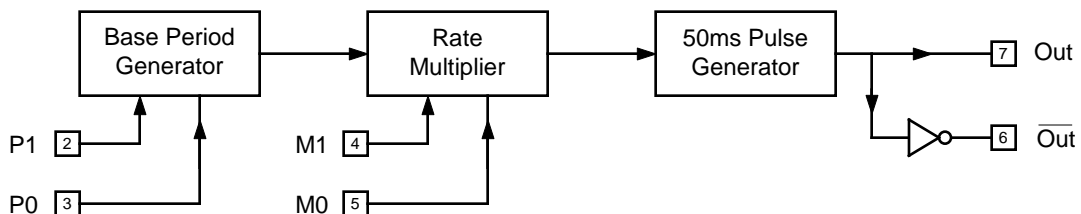

P1	P0	Period
L	L	1 sec
L	H	2 sec
H	L	5 sec
H	H	6 sec

M1	M0	Multiplier
L	L	0.1
L	H	1
H	L	10
H	H	100



Pin Descriptions

V_{DD} (pin 1)

This pin is the positive supply pin, and should always be the most positive point in the circuit. Internal circuitry connected to this pin is used to provide power on reset of the microprocessor, so an external reset signal is not required. Refer to the Electrical Characteristics section for further information.

P1 (pin 2) and P0 (pin 3)

These two pins are used to select the base period for oscillation. P1 is the most significant bit, and P0 is the least. See the chart on page 1 for possible states of P1 and P0, and the resulting periods.

M1 (pin 4) and M0 (pin 5)

These two pins determine the multiplier that should be applied to the base period in order to

determine the actual period of oscillation. Values of 0.1, 1, 10 and 100 are possible as shown in the chart on page 1.

Out (pin 6) and Out (pin 7)

These are the two output pins. Pin 6 is normally held at a logical high level, and pin 7 at a logical low. Each pin reverses its state for a period of 50ms at the beginning of each timing cycle, independent of the overall period selected.

V_{SS} (pin 8)

Circuit common is connected to this pin. This is the most negative point in the circuit.

Ordering Information

These integrated circuits are available in either the 300 mil plastic DIP format, or in the 200 mil SOIC surface mount type of package. To order, add the appropriate suffix to the part number:

300 mil Plastic DIP..... ELM460P

200 mil SOIC..... ELM460SM

Absolute Maximum Ratings

Storage Temperature..... -65°C to +150°C

Ambient Temperature with
Power Applied..... -40°C to +85°C

Voltage on V_{DD} with respect to V_{SS}..... 0 to +7.5V

Voltage on any other pin with
respect to V_{SS}..... -0.6V to (V_{DD} + 0.6V)

Note:

Stresses beyond those listed here will likely damage the device. These values are given as a design guideline only. The ability to operate to these levels is neither inferred nor recommended.

All rights reserved. Copyright ©1999 Elm Electronics.

Every effort is made to verify the accuracy of information provided in this document, but no representation or warranty can be given and no liability assumed by Elm Electronics with respect to the accuracy and/or use of any products or information described in this document. Elm Electronics will not be responsible for any patent infringements arising from the use of these products or information, and does not authorize or warrant the use of any Elm Electronics product in life support devices and/or systems. Elm Electronics reserves the right to make changes to the device(s) described in this document in order to improve reliability, function, or design.

Electrical Characteristics

All values are for operation at 25°C and a 5V supply, unless otherwise noted. For further information, refer to note 1 below.

Characteristic	Minimum	Typical	Maximum	Units	Conditions
Supply Voltage, V_{DD}	3.0	5.0	5.5	V	
V_{DD} rate of rise	0.05			V/ms	see note 2
Average Supply Current, I_{DD}		1.0	2.4	mA	
Input low voltage	V_{SS}		$0.15 V_{DD}$	V	
Input high voltage	$0.85 V_{DD}$		V_{DD}	V	
Output low voltage			0.6	V	Current (sink) = 8.7mA
Output high voltage	$V_{DD} - 0.7$			V	Current (source) = 5.4mA
Output Pulse Period		50		msec	see note 3

Notes:

1. This integrated circuit is produced with a Microchip Technology Inc.'s PIC12C5XX as the core embedded microcontroller. For further device specifications, and possibly clarification of those given, please refer to the appropriate Microchip documentation.
2. This spec must be met in order to ensure that a correct power on reset occurs. It is quite easily achieved using most common types of supplies, but may be violated if one uses a slowly varying supply voltage, as may be obtained through direct connection to solar cells, or some charge pump circuits.
3. Pulse timing is affected by supply and temperature variations as shown in Figure 1 below. Results shown are average values that can be expected.

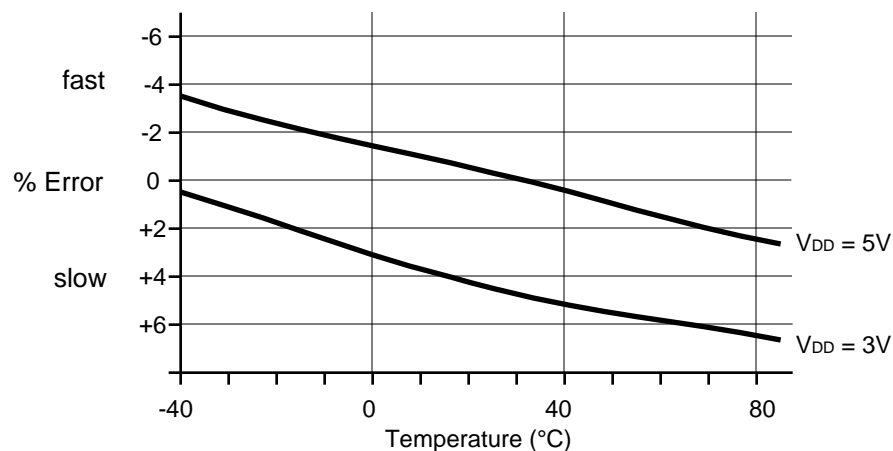

Figure 1. Average Timing Error

Example Applications

Uses for the ELM460 are numerous and only limited by the imagination of the designer. Any circuit where events are expected to occur on a regular basis are typical applications for this device. Two example uses are shown below.

Figure 2 shows the ELM460 used to continuously operate a stepper motor, using an ELM311 stepper motor controller. The ELM460 is connected to constantly provide a step input at a rate of 10 steps per second (P1=L, P0=L, M1=L and M0=L).

Figure 3 below shows another use for the ELM460, directly driving an LED. The circuit is configured to provide 1 flash every 2 seconds (P1=L, P0=H, M1=L and M0=H). Although the IC is capable of both sinking and sourcing relatively high currents, it's sink capabilities are slightly greater than it's source (for a given output V_{ds} voltage drop) and that is exploited here, by sinking the LED current. As always, a V_{DD} bypass capacitor is shown in the schematic, as it is good practice to include one.

This type of flasher circuit might seem ideal at first for burglar alarm type warning LEDs, and it would be for many installations. Consideration should be given however, to the fact that the ELM460 draws about 1mA continuously from the supply. This might be too much for some battery powered systems.

The ELM460 can be easily employed in many circuits where timers such as the '555 or '2240 are currently used in, without the need for timing capacitors or charge and discharge resistors. Although the operating voltage ranges are different, and the output current drive of the '460 is not as great as the '555, the ease in which it is connected, and its ability to be programmed with logic level signals, are appealing to the designer. All of these types complement one another, however, and each should be chosen on its merits for the particular application.

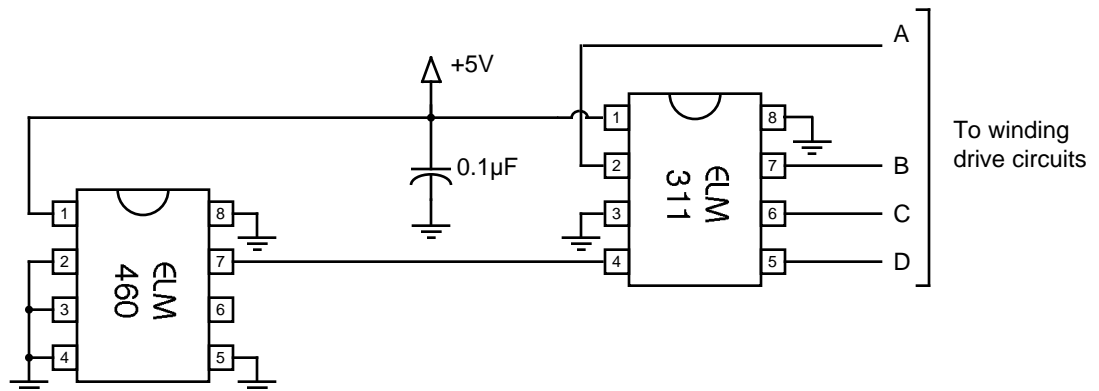

Figure 2. Continuously Running a Stepper Motor

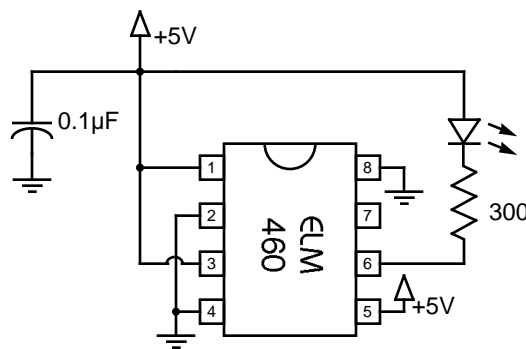

Figure 3. LED Flasher