



ELM621

Serial Three Bit Port

Description

The ELM621 is a serially controlled, three bit parallel I/O port in an 8 pin package. The high level of integration employed means that very few external components are required in order to construct a fully functional circuit with this IC.

The ELM621 offers several convenient features that many users will appreciate. The provision of a 16 byte buffer allows commands to be chained and executed sequentially with one key stroke. The controllable pullup resistor on the bit 3 port pin is particularly helpful when interfacing to mechanical switches, while the ability to control character echo reduces overhead while operating under computer control. Naturally, individual as well as simultaneous read, set, clear and toggle commands are also supported.

All communications with this device are via a standard 9600 baud RS232 connection, using AT style commands. No special characters are required, so that virtually any terminal program can be used with the ELM621. More advanced users will be interested in operating this device under computer program control – simply a matter of writing to and reading from the device.

Features

- Low power CMOS design - typically 1mA
- High speed (9600 baud) RS232 communications
- Standard ASCII commands and responses
- 16 byte receive buffer
- Switchable pullup resistance
- Minimum of external components required
- External reset input
- High current drive outputs - up to 25 mA

Applications

- Home automation monitoring and control
- Robotics
- Security monitoring
- IC programmers

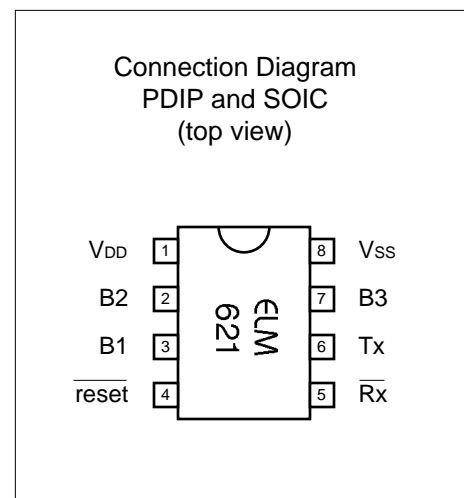

Block Diagram

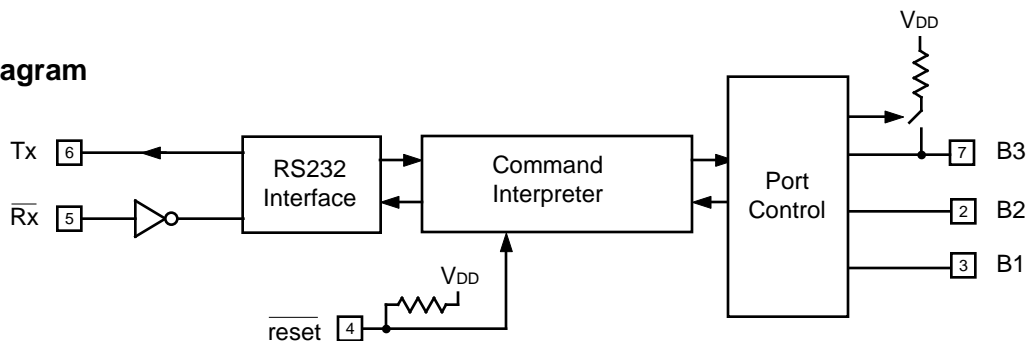



Pin Descriptions

V_{DD} (pin 1)

This pin is the positive supply pin, and should always be the most positive point in the circuit. Internal circuitry connected to this pin is used to provide power on reset of the microprocessor, so an external reset signal is not required. Refer to the Electrical Characteristics section for further information.

B1 (pin 3), B2 (pin 2) and B3 (pin 7)

These are the three port pins that are software configurable. At power-up, and after resetting, these pins are inputs but can be individually set as either input or output. The B3 pin has an internal (nominally 30K) pullup resistor that can be enabled or disabled as required.

reset (pin 4)

This pin can be used to reset the circuit by applying a momentary logic low level to it. If unused, this pin should be left open (as a pullup resistor is provided) or connected to V_{DD}.

R_x (pin 5)

This is the RS232 receive input. Internal inversion of the logic level allows the pin to be directly connected to the DTE's TxD line through a single current limiting resistor (typically about 47K). Precautions should be taken in the circuit design to allow for the possibility that this input may be left floating, due to a disconnected serial cable. Typically, this only requires a large-valued resistor between the RS232 TxD pin and V_{ss}.

Tx (pin 6)

The RS232 data output pin. Signal level is compatible with most inverting interface ICs, and drive is sufficient to allow interfacing using only a single PNP transistor. See the Example Application section for more details.

V_{ss} (pin 8)

Circuit common is connected to this pin. This is the most negative point in the circuit.

Ordering Information

These integrated circuits are available in either the 300 mil plastic DIP format, or in the 200 mil SOIC surface mount type of package. To order, add the appropriate suffix to the part number:

300 mil Plastic DIP..... ELM621P

200 mil SOIC..... ELM621SM

All rights reserved. Copyright ©1999 Elm Electronics.

Every effort is made to verify the accuracy of information provided in this document, but no representation or warranty can be given and no liability assumed by Elm Electronics with respect to the accuracy and/or use of any products or information described in this document. Elm Electronics will not be responsible for any patent infringements arising from the use of these products or information, and does not authorize or warrant the use of any Elm Electronics product in life support devices and/or systems. Elm Electronics reserves the right to make changes to the device(s) described in this document in order to improve reliability, function, or design.



Absolute Maximum Ratings

Storage Temperature..... -65°C to +150°C
 Ambient Temperature with
 Power Applied..... -40°C to +85°C
 Voltage on V_{DD} with respect to V_{SS}..... 0 to +7.5V
 Voltage on any other pin with
 respect to V_{SS}..... -0.6V to (V_{DD} + 0.6V)

Note:
 Stresses beyond those listed here will likely damage the device. These values are given as a design guideline only. The ability to operate to these levels is neither inferred nor recommended.

Electrical Characteristics

All values are for operation at 25°C and a 5V supply, unless otherwise noted. For further information, refer to note 1 below.

Characteristic	Minimum	Typical	Maximum	Units	Conditions
Supply Voltage, V _{DD}	4.5	5.0	5.5	V	
V _{DD} rate of rise	0.05			V/ms	see note 2
Average Supply Current, I _{DD}		1.0	2.4	mA	
Logical low input voltage	V _{SS}		0.15 V _{DD}	V	
Logical high input voltage	0.85 V _{DD}		V _{DD}	V	
Output low voltage			0.6	V	Current (sink) = 8.7mA
Output high voltage	V _{DD} - 0.7			V	Current (source) = 5.4mA
Internal pullup resistances (see note 3)	300	500	600	K	$\overline{\text{reset}}$ (Pin 4)
	20	30	50	K	B3 (Pin 7) when enabled
$\overline{\text{Rx}}$ pin input current	-0.5		+0.5	mA	see note 4
RS232 Baud Rate		9600		baud	see note 5

Notes:

1. This integrated circuit is produced with a Microchip Technology Inc.'s PIC12C5XX as the core embedded microcontroller. For further device specifications, and possibly clarification of those given, please refer to the appropriate Microchip documentation.
2. This spec must be met in order to ensure that a correct power on reset occurs. It is quite easily achieved using most common types of supplies, but may be violated if one uses a slowly varying supply voltage, as may be obtained through direct connection to solar cells, or some charge pump circuits.
3. The value of the internal pullup resistance is both supply and temperature dependent.
4. This specification represents the current flowing through the protection diodes when applying large voltages to the Rx (pin 5) input through a current limiting resistance. Currents quoted are the maximum continuous.
5. The RS232 baud rate is derived from an internal oscillator that can typically vary by about ±3% over the full temperature range with V_{DD} = 5V. Data is transferred to and from the ELM621 with 8 data bits, no parity, and 1 stop bit (8 N 1).



Design Considerations

The ELM621 makes it easy to quickly construct a control circuit, but may be frustrating if you don't keep a few things in mind. Here are some pointers to consider...

When two power supplies are involved, always try to have the ELM621 powered at either the same time, or before applying power to the other circuitry. Failing to do so may allow backfeed through the (inherent) port pin protection diode, causing unexplained and possibly erratic operation.

Keep in mind that this is a CMOS integrated circuit, and that 'latch-up' of the chip can thus occur. To reduce the possibility, keep connecting cables as short as possible, and consider placing a small value resistor (100 to 220 Ω) in series with the port pins.

The RS232 interface is not complicated, but consideration must be given to the fact that the receive signal is inverted from what would normally

be expected. This simplifies the RS232 interface circuitry, but may result in some confusion. Refer to the Example Application section for a typical method of connection.

Under high-speed computer control, problems may result due to the fact that there are no hand-shaking signals provided. This is generally not a problem if controlled by keyboard entry, as the ELM621 is considerably faster than a human typist, but under software control, one should always wait for the prompt ('>') character before issuing another command.

As a final note, it should be realized that linefeed characters are not sent by the ELM621 with the carriage returns. If viewing the output on a terminal, many users may wish to have their terminal program add the linefeeds in order to improve readability.

The Command Line Interpreter

All commands are transmitted to the ELM621 one line at a time. A line consists of the character 'A' followed immediately by the letter 'T', then up to 16 control characters, and a terminating carriage return character (0x0D). The carriage return serves as an execute command, the line not being translated and executed until this character is received.

The 16 byte command buffer is implemented as a 'first-in first-out' (FIFO) type, retaining only the most recent 16 characters since the last AT. Any other characters are lost (there is no scroll-back capability). The buffer is not cleared immediately after executing a command line. This allows for a 'command line repeat' mode if a carriage return is received immediately after executing a line. Receipt of any other character will clear the buffer. This feature is particularly useful when simply toggling a bit on and off, or stringing two toggles together to form a pulse in order to trigger another circuit.

A command line may contain spaces or commas between the individual commands, as these do not affect operation. Often when using a terminal, it is convenient to separate commands with one of these characters in order to improve readability, but keep

in mind that all two-character commands must not have a comma or space between the two characters.

One other feature of the interpreter is that it is not case-sensitive. That is that it is able to accept either upper or lower case characters in the input, and they are treated equally (an 'A' is treated the same as 'a', 'T' is the same as 't', etc.)

Error reporting by the ELM621 is quite minimal. Checking of a line for errors does not occur until after the carriage return is received, and any error in the input is reported with a simple question mark. If there is any error detected in the syntax of a line, none of the line is executed.

Occasionally there may be delays in the transmission from the controlling device to the ELM621, either due to the operator pausing, or to a break in the communications channel. When a pause of greater than 20 seconds occurs, the ELM621 will time out and automatically return to its 'waiting for AT' state.



AT Commands

The following lists the commands that the ELM621 recognizes. These are collectively referred to as 'AT' commands due to the fact that each line must be preceded by the letters 'A' and 'T'.

All commands except reset ('Z') require two characters to be complete. The first is a descriptive letter, while the second is chosen from one of the

options shown within the square brackets, adjacent to the letter.

As an example, the R or read command can be followed by either a 1, 2, 3, or an A, so to read the state of bit 2, the command 'AT R2' would be issued, and AT RA will read all bits.

Device Control

E [1 | N] - terminal echo on

Selecting either E1 or EN will cause all characters sent to the ELM621 to be retransmitted (or echoed) back to the controlling device.

E [0 | F] - terminal echo off

Selecting either E0 or EF will stop the echoing of characters back to the controlling device.

ID - show the device identification string

This command is used to display the type of device connected and the ROM version.

Z - reset

This command is used to reset the ELM621 to the power on state. All three port pins will be configured as inputs, the pullup resistor will be off, the output latches will be cleared, and terminal echo will be on.

Port Control

I [1 | 2 | 3 | A] - set port bit to input

Individually selects one, or simultaneously selects all pins to be inputs, turning off the respective output driver if it were on.

O [1 | 2 | 3 | A] - set port bit to output

Selects one or all pins to be outputs, enabling the respective output drivers. If the pullup were on, and O3 or OA were issued, then the pullup would be temporarily disabled. Returning B3 to the input state would restore the pullup resistance.

P [1 | N] - turn the B3 pullup resistance on

Selecting either P1 or PN will enable the internal 30K resistor from pin 7 to V_{DD}.

P [0 | F] - turn the B3 pullup resistance off

Selecting either P0 or PF will disable the internal 30K resistor from pin 7 to V_{DD}.

Bit Control

C [1 | 2 | 3 | A] - clear the output bit

Individually clears (to logic 0 or V_{SS}) either one or all of the port bits. If the pin(s) are also selected to be outputs, then the logic level will appear immediately on the output.

S [1 | 2 | 3 | A] - set the output bit

Individually sets (to logic 1 or V_{DD}) either one or all of the port bits. If the pin(s) are also selected to be outputs, then the logic level will appear immediately on the output.

T [1 | 2 | 3 | A] - toggle the state of the output bit

Reverses (or toggles) the logic level of the selected pin(s). As with C or S, the pin(s) must also be selected as outputs for an external change to occur. The toggle command is convenient for creating pulses, or strobes, on pins. For example, if bit 3 is configured as an output, and is at a low level, issuing the command AT T3 T3 will cause pin 7 (B3) to momentarily go to a high level, then return low. As the ELM621 is interpreter driven, the width of the pulse will be related to the number of characters that need be translated. Minimum width (~60µsec) is obtained with ATT3T3.

R [1 | 2 | 3 | A] - read the level of the port pin

Reads the voltage level at the selected pin(s) and reports the measured logic level. For example, if pin 2 is at V_{DD} (logic 1), then issuing AT R2 will result in a response of B2=1.

Example Application

Figure 1 shows how the ELM621 would typically be connected in a circuit. The three port pins have been wired to control an LED and a relay, as well as monitor the state of a pushbutton.

Since the relay requires 12V for its operation, the main supply for this circuit would likely be 12V, with the +5V derived from this using a regulator (typically a 78L05). Alternatively, many computers have 5V and 12V available that may be used. The actual source is not critical for this application, so is not discussed further here.

The RS232 interface circuitry shown is very basic, but completely adequate. Rather than use a dual supply and RS232 drivers, the circuit 'steals' negative voltage from the controlling device's Tx/D line, and uses it to provide the negative bias for the ELM621's output via the PNP transistor. The PC connected to this port should be set for 9600 baud, 8 data bits, no parity, and either 1 or 2 stop bits.

The relay and LED drive circuits shown are conventional types. An NPN transistor is used to increase current drive while interfacing to the relay's 12V supply, while the LED is simply driven directly by the B1 port pin.

The pushbutton is wired to B3 with a 1K resistor in series to provide some protection against electrostatic damage. This resistor is not essential if the switch is

mounted nearby, but is good practice. The switch uses the B3 internal pullup resistance to provide 'wetting' voltage. Assuming the chip has just been reset, this resistance is enabled in the initiating statement:

```
AT O1 O2 PN
```

The above statement sets both B1 and B2 to outputs, while leaving B3 as an input with the pullup resistance on.

To turn the relay (B2) on, one then needs only issue:

```
AT S2
```

while it will be turned off with:

```
AT C2
```

Alternatively, AT T2 could have been used, followed by a single carriage return character each time that a state change is required. Control of the LED is similar, requiring an S1 to turn it on, and a C1 to turn it off.

The pushbutton switch state can be determined by issuing a read command of bit 3:

```
AT R3
```

When the switch is pressed, the response will be B3=0, otherwise it will be B3=1 (due to the internal pullup).

That should get you started. Perhaps with a some programming, the interface could be used to monitor a thermostat and turn the heat on, or control a robot, or write data to an EEPROM ...

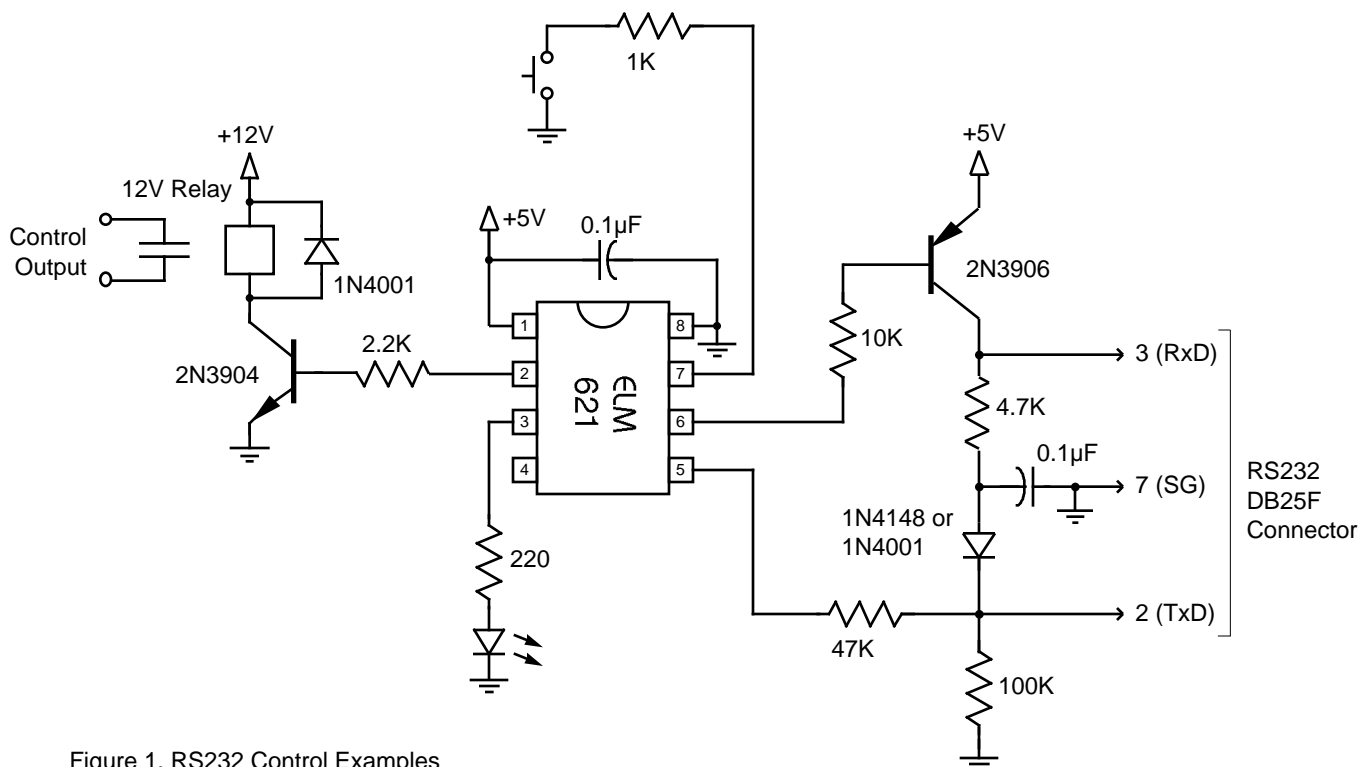

Figure 1. RS232 Control Examples